

Stowable Lund Chair

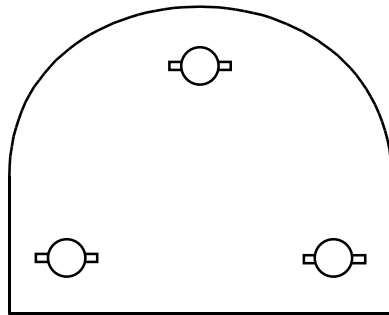

Top (or underside)

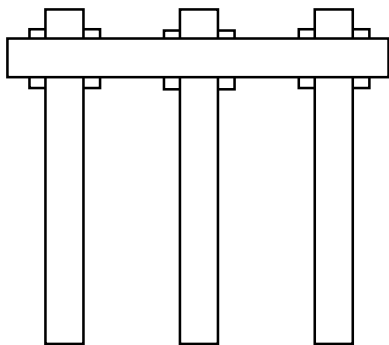
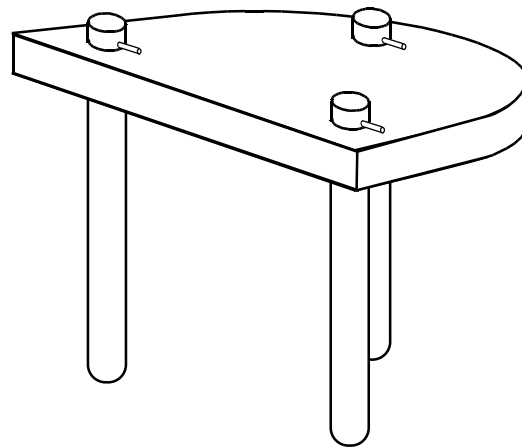

Front or Back

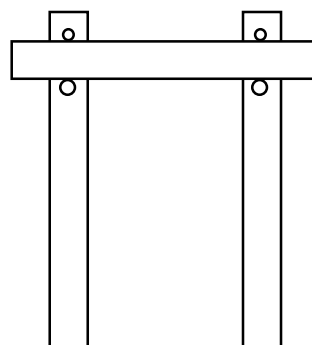

Side

List of Materials:

Plank, 1.5"- 2.0" thick by 20" long x 14" wide or as close as you can get. Length and width will depend on how much seat area you require.

One length of round stock 1.25"-1.50" diameter by 60" long. If you can find 2.0", even better. This will be cut into 3 equal pieces, depending on how tall you want your stool.

1 small dowel for top pins, 0.25" diameter by 9.0" long, cut into 3 equal lengths

1 larger dowel for bottom pins (load bearing), 0.375" diameter by 9.0" long.

Directions for Assembly:

Cut round edge in plank to your taste with apex of curve centered on opposite side of plank.

Drill 3 holes with hole saw to size. If you want to angle hole, use no more than a 10 degree angle from centerline of stool.

Cut large round stock to length (if you angle cut your holes, be prepared to angle cut your legs at the same angle top and bottom.

Carefully measure how much you want the top of the legs poking out from the seat. There needs to be enough room to drill a hole for the top pin to fit snugly.

Likewise, carefully drill the bottom hole (load bearing portion of leg) so it is tight against the bottom of the seat.

Tap bottom pins in place, insert legs into seat. Tap top pins into place.

Enjoy your Lund style seat.

If you want to make a bench, use a longer piece of wood and add the 4th leg. All other assembly instructions are the same.